

## UPSC Daily Current Affairs| Prelim Bits 14-02-2025

### World Government Summit (WGS) 2025

#### Why in News?

Recently, the 12<sup>th</sup> edition of World Government Summit (WGS) 2025 was held in Dubai, United Arab Emirates (UAE).

- **Established in - 2013.**
- **Theme** - Shaping Future Governments.
- **Aim** - To empower young Arabs through mentorship and educational initiatives.
- **WGS** - It serve as a ***platform for global dialogue*** on the future of governance, innovation, and sustainable development.
- **Participation** - Over 30 heads of state and more than 400 ministers at International level.
- **Composition** - It includes several forums such as:
  - Future of Work Forum, Government Experience Exchange Forum, Government Services Forum, Artificial Intelligence Forum, Future of Education Forum, Future of Mobility Forum, and Gender Balance Forum.
- **Meeting for Young Leaders** - It promoting youth involvement in governance and partnerships with decision-makers.
- It provides sessions to help young people gain skills for future leadership roles.
- It includes addressing critical challenges that governments face and aiming to shape future policies and practices.
- **India's Contributions**
- **2 key priorities:**
- Capacity building in *clean technology*, electric vehicles, and climate-resilient infrastructure.
- Securing adequate financial resources to achieve the Sustainable Development Goals (SDGs), particularly in combating *climate change* and safeguarding environmental systems.
- **Commitment** - To green growth, afforestation, sustainable agriculture, and the development of green infrastructure as integral components of its development strategy.

**Mission LiFE** (Lifestyle for Environment) initiative, promotes a pro-planet lifestyle that embraces sustainability at individual, community, and national levels, ensuring that the choices we make today contribute to a better future.

## Reference

[DD News| World Government Summit 2025 India's Focuses](#)

### 14<sup>th</sup> Asian Fisheries and Aquaculture Forum (14AFAF)

#### Why in News?

Recently, the Minister of Fisheries, Animal Husbandry & Dairying inaugurated the 14<sup>th</sup> Asian Fisheries and Aquaculture Forum (14AFAF) in New Delhi.

- **AFAF** - It is a **scientific forum** organized once in every 3 years.
- **Organized by** - Asian Fisheries Society (AFS).
- **14AFAF Theme** - Greening the Blue Growth in Asia-Pacific.
- **Aim** - To address key issues towards developing sustainable fisheries and aquaculture.
- **Purpose** - To provide an **international platform** for eminent scientists, young researchers, and other stakeholders across the globe to share their research experiences and innovative ideas.
- **Global Collaboration** - It focus on fostering cooperation in fisheries and aquaculture.
- It serves as an international collaboration, uniting stakeholders from various nations to discuss innovations in the fisheries sector.
- It uses the technologies, concentrating on improving fish varieties and production methods.
- **India's contributions** - To fisheries, enhances international relations, and promotes sustainable fish production.
- To enhance partnerships and propel initiatives for a sustainable and resilient fisheries industry.

*India emerged as the **world's 2<sup>nd</sup> largest** producer in the total fish and aquaculture production.*

- **Fisheries Initiatives:**
- **Pradhan Mantri Matsya Sampada Yojana (PMMSY)** - It is a flagship program aimed at *boosting fish production*.
- **Digital solutions** - National Digital Fisheries Platform are being rolled out, featuring vessel monitoring systems and *emergency alerts for fishermen*.
- **Kisan Credit Card scheme** - It is now available for fishers, providing essential financial assistance.
- **Technological Advancements** - Indian Council of Agricultural Research (ICAR) has developed 75 innovative fisheries technologies focused on fostering sustainable and carbon-neutral aquaculture practices.

## References

1. [14afaf| 14th Asian Fisheries and Aquaculture Forum \(14AFAF\)](#)
2. [Krishi Jagran| India's Rise in Fish Production.](#)

# HAMMER Weapon System

## Why in News?

Bharat Electronics Limited (BEL) and France's Safran Electronics & Defense have formed to produce the HAMMER Weapon System.

- **HAMMER** - Highly Agile Modular Munition Extended Range.
- It is a **smart precision guided air-to-ground weapon** in India.
- **Capabilities** - It is an all-weather smart air-to-surface weapon with an extended stand-off capacity.
- It provides accurate targeting of ground assets.
- **Coverage** - It is a **combat-proven weapon system** known for its high accuracy and modular design making it adaptable for multiple platforms including the Rafale and LCA Tejas.
- All the tactical requirements of air forces due to different guidance kits.

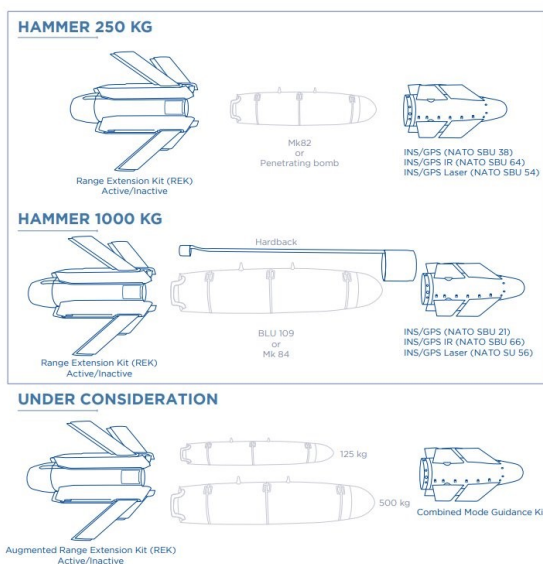

## A VERSATILE AND MODULAR WEAPON SYSTEM



### UNCHALLENGED ACCURACY

- HRG Crystal™ high-grade inertial system ensuring accuracy in GNSS-denied environment in all weather conditions.
- Three guidance kit versions to cover the full spectrum of air-to-surface tactical mission requirements.
- Common INS/GPS guidance for each guidance kit.



<b>+ IR GUIDANCE</b>		<ul style="list-style-type: none"><li>➤ Use of digital scene matching algorithms in terminal phase</li><li>➤ Design to work with vertical AOI**</li></ul>
<b>+ LASER GUIDANCE</b>		<ul style="list-style-type: none"><li>➤ Use of laser sensor in terminal phase</li><li>➤ Fast-moving targets</li></ul>

\*for all weather conditions. \*\*AOI: Angle Of Impact - \*\*\*Hemispherical Resonator Gyroscope



### HRG CRYSTAL™ Rebooting the navigation revolution

Mass-produced in Montluçon in France, Safran's HRG\*\*\* Crystal™ is the latest generation of cutting-edge resonating gyroscope designed to address the most demanding military navigation requirements. Embedded with HRG Crystal™, Safran's HAMMER has successfully reached its target in more than **3,000 strikes with the highest level of accuracy.**

- **Focus** - Joint venture on localizing the production of the HAMMER weapon system, supporting India's Atmanirbhar Bharat initiative to reduce imports.
- The partnership will involve technology transfer from Safran to BEL, allowing BEL to manage final assembly, testing, and quality assurance, creating opportunities for Indian industries, especially SMEs.
- Establishment of centre of excellence to enhance India's defense capabilities in optronics and navigation equipment for military applications.
- **Long-term agreement** - HAL's agreement with Safran for the LEAP engine includes producing forged turbine components to boost India's aviation manufacturing and self-sufficiency.
- **Employment Opportunity** - It will facilitate to create 400 jobs and aim to produce 30,000 equipment units annually by 2026.
- **Past collaborations** - HAL and Safran include the Shakti helicopter engine and

current developments for the Indian Multi-Role Helicopter.

- It underscores the importance of localizing defense production and enhancing India's manufacturing capabilities in advanced technologies.

## References

1. [The Hindu| HAMMER Weapon](#)
2. [Safran| AASM HAMMER](#)

### One Liners 14-02-2025

#### Polity & Governance

##### Pradhan Mantri Anusuchit Jaati Abhyuday Yojana (PM-AJAY)

- **Launched in** - 2021-22.
- **Nodal Ministry** - Ministry of Social Justice & Empowerment.
- **PM-AJAY** - It is a *merged scheme of 3* centrally sponsored scheme namely,
  - Pradhan Mantri Adarsh Gram Yojana (PMAGY).
  - Special Central Assistance to Scheduled Castes Sub Plan (SCA to SCSP).
  - Babu Jagjivan Ram Chhatrawas Yojana (BJRCY).
- **Aim** - To reduce poverty of the SC communities by generating additional employment opportunities through skill development, income-generating schemes, and other initiatives.

##### Amrit Sarovar Scheme

- **Launched in** - 2022.
- **Initiated by** - Ministry of Rural Development.
- **Aim** - At developing/rejuvenating *75 Amrit Sarovars (ponds)* in each district, totaling 50,000 across the country.
- **Objective** - To conserve water for the future.
- **Phase II** - To continue with a renewed focus on ensuring water availability, with community participation (Jan Bhagidaari) at its core.
- **Mission involves collaboration** - Ministry of Rural Development and the Ministry of Water Resources, Bhaskaracharya National Institute for Space Application & Geoinformatics (BISAG-N).

##### Pradhan Mantri Dakshata Aur Kushalata Sampanna Hitgrahi (PM-DAKSH)

- **Launched in** - 2020-21.
- **Launched by** - Ministry of Social Justice & Empowerment.
- **Aim** - To *empower target marginalized session by boosting their skills* to improve their employability and income prospects.
- **Target Groups:**
  - **Artisans** - who can enhance their revenue in their trades.
  - **Women** - who can achieve self-employment and financial empowerment while balancing domestic responsibilities.
  - **Youth** - who can gain training and specialization for better job market prospects.
  - SCs & OBCs.
- **Age criterion** - 18-45 years.
- **Timeline** - *5 years* (2021-2026).

### **Madak-Padarth Nished Asoochana Kendra (MANAS)**

- **Operated by** - Narcotics Control Bureau.
- **Nodal Ministry** - Ministry of Home Affairs.
- **MANAS** - It is a *National Narcotics Helpline Portal* stands as a digital initiative.
- **Aim** - To stop drug supply by catching importers and preventing production and sales.
- **Features** - It is an integrated system providing a single platform for citizens to log, register, track and resolve drug related issues/ problems through various mode of communications like call, SMS, Chat-bot, email & web-link.
- To provide *toll-free 24x7 telecom service* to drug addicts, informers, and citizens seeking support and information.

### **Nasha Mukh Bharat Abhiyaan (NMBA)**

- **Launched on** - **15<sup>th</sup> August 2020 (Independence Day)** Against Drug Abuse and Illicit Trafficking.
- **Launched by** - Ministry of Social Justice & Empowerment.
- **Objective** - Preventive measures, mass education, service provider training, partnerships, and treatment facilities.
- It is for 272 Districts across 32 State/UT that have been identified as the most vulnerable in terms of usage of drugs in the country.

### **Schedule 'M' of Small And Medium Manufacturers**

- **Part of** - Drugs and Cosmetics Act, 1945.
- **Schedule M** - It outlines *Good Manufacturing Practices (GMP)* for pharmaceutical products in India.
- **Coverage** - The requirements for premises, plants, and equipment used in the manufacturing process.
- **Types:**
  - Schedule M - 1 is titled "Good Manufacturing Practices and Requirements of Premises, Plant and Equipment for Homoeopathic Medicines".
  - Schedule M - 3 is titled "Quality Management System -For Notified Medical Devices and In-Vitro Diagnostics".
- **Revised Schedule M** - GMP was upgraded to "good manufacturing practices and requirements of plan and equipment for pharmaceutical products".

## **Science**

### **Epilepsy**

- **Epilepsy** - It is a *chronic non-communicable disease* of the brain that affects people of all ages.
- **Conditions** - Recurrent *seizures of involuntary movement* that may involve a part of the body or the entire body.
- **Symptoms** - Vary and depend on where the disturbance first starts in brain and how far it spreads.
  - Loss of awareness, consciousness, disturbances of movement, sensation (including vision, hearing & taste), mood etc.
- Around 50 million people worldwide have epilepsy which make it one of the *most common neurological diseases* globally.

## **International Epilepsy Day**

- **Celebrated on** - 2<sup>nd</sup> Monday of February every year.
- **Organised by:**
  - International Bureau for Epilepsy (IBE)
  - International League Against Epilepsy (ILAE).
- **Theme 2025** - My Epilepsy Journey.
- **Aim** - To raise awareness about epilepsy, a common neurological disorder that can affect anyone, at any age.
- An estimated 4.7 million people with epilepsy live in the Eastern Mediterranean Region.

## **Index**

### **Devolution Index Report**

- **Released by** - Ministry of Panchayati Raj & Ministry of Fisheries, Animal Husbandry and Dairying.
- It specifically examines how autonomous panchayats are to make and implement independent decisions, reflecting the true spirit of Article 243G of the Constitution.
- **Evaluation** - Based on 6 critical dimensions:
  1. Framework
  2. Functions
  3. Finances
  4. Functionaries
  5. Capacity Building
  6. Accountability of the Panchayats.
- It provides insights into the progress of decentralization across states and union territories.